

For customer

HITACHI
Inspire the Next



INK JET PRINTER FOR INDUSTRIAL MARKING

HITACHI Printer

Handling Guidance and Precautions for Ink



- ◆ Please read SDS(Safety Data Sheet) of purchased ink and makeup.
- ◆ Before using IJ printer, please read following precautions for stable operation.
- ◆ Please refer "Basic Operation Manual", "Instruction Manual" and "Technical Manual" also.

 WARNING	WARNING is used to indicate the presence of a hazard which may cause severe personal injury or death if the warning against performing an incorrect handling procedure is ignored.
 CAUTION	CAUTION is used to indicate the presence of a hazard which may cause personal injury or property damage if the warning against performing an incorrect handling procedure is ignored.

Version; W5.03

Basic Precautions

[i]

Precautions of Storage

- (1) Please read SDS(Safety Data Sheet) of purchased ink and makeup.
- (2) Store inks and makeups in the cold dark place (0 to 20°C).(Please store them in the same way regardless before and after opening cartridge/bottle.)
- (3) There is an opening deadline for inks and makeups. Please fill them into the IJ printer before the "Expiration date" described on the cartridge/bottle. ("Expiration date" means "Opening deadline".)
- (4) Once the cartridge/bottle is opened, even if it is stored in a cold dark place, the ink begins to deteriorate in the same manner as the ink in the printer. If "Ink Replacement Cycle" base on guideline have passed, dispose the ink.

[Note] Regarding to (3) and (4), please see detail on following "[v] Guideline for the "Ink Replacement Cycle" and applicable makeup" .



WARNING

Do not drain the ink or makeup waste solution into public sewer systems or elsewhere. Waste disposal must comply with all appropriate regulations. Have the used wiping papers and the empty container disposed by an industrial waste processor. Consult the appropriate regulatory agency for further information.

[ii]

Consideration of "Air purge" Install

Depend on usage environment, air purge is necessary. Below is the conditions under which air purge is required.(*1).

- (1) When the printer is used in a high-humidity environment, such as a beverage can or beer can line (Perform air purge when using it in the 85 % RH or higher humidity environment.)
- (2) When a water drainage blow sequence is performed before printing.
- (3) When you use the printer in an environment with a lot of paper powder or dust.
- (4) When the end of the print head becomes dirty because the distance between the print head and the target is too close and ink splashing occurs.
- (5) When you use the ink for which the need for air purge is described in the handling guidance of each ink.

[Note] Depending on the ink, "Air purge" is required regardless of the usage environment.
On the contrary, there is case installing is not available. Please see "Precautions for each ink".

(*1) UX2/UX/RX2 : [Technical Manual] 3.1 Print head air purge

[iii]

Print Head Cleaning

Take the following precautions when cleaning ink from around the nozzle.

- (1) Face the end of the print head downward and pour makeup onto the dirty part and clean while catching the makeup in a beaker.

Do not pour the makeup over this section.
Wipe the print head clean with wiping paper dampened with the makeup.

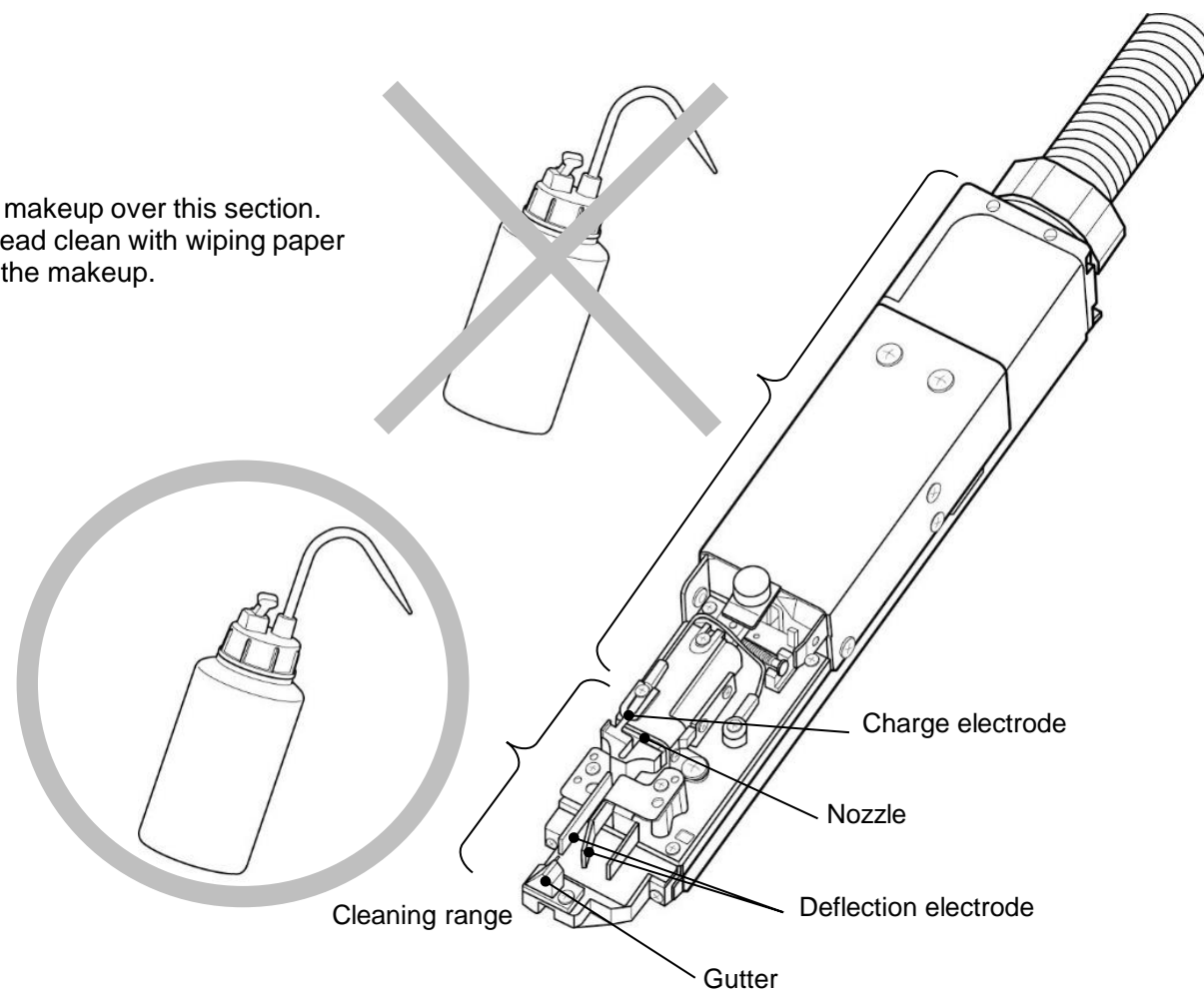

*This figure is an image of UX2 series. There are some difference between UX2 and UX/RX2, but basic structure is same.

- (2) After cleaning, thoroughly wipe the print head with wiping paper and allow it to dry.
 - Thoroughly dry the nozzle orifice, charge electrode, deflection electrode, and mounting base and fringe of the gutter. Make sure that the parts are sufficiently dry before starting the next operation. If operated while wet, the printer will not start normally.
 - While the print head is wet, do not orient its end upward.
- (3) Do not immerse the print head in the makeup.
- (4) When printing is frequently performed or the distance between the print material and the print head is short, ink splashes may stain the end of the print head and the print head cover. If this condition is left unresolved, the staining will be worse, resulting in a print error or emergency stop. If a print error or emergency stop frequently occurs due to staining caused by ink splashes, stop the operation in progress and clean the end of the print head (around the nozzle, charge electrode, deflection electrode, mounting base and gutter) and the print head cover. Perform this operation in addition to the cleaning at the end of each day's work.

Air purging of the print head is effective against staining due to ink splashing. See the "Print head air purge(*1)".

(*1) UX2/UX/RX2 : [Technical Manual] 3.1 Print head air purge

[iv]

Gutter Cleaning

This unit collects ink from the gutter. At the same time, it sucks in atmospheric gas, dust, and other matter from the air. If these substances are mixed with the ink in the gutter, undissolved components in the ink or makeup may stick to the gutter. If the unit runs for a long time without the gutter being cleaned, these components will gradually accumulate in the gutter. This, together with the ink coming into contact with it, may cause an error stemming from a dirty head.

If this fault occurs, perform the following actions (1) and (2):

- (1) Clean the gutter and its perimeters with makeup periodically.
- (2) See the procedures described in the Technical Manual "Cleaning the Gutter(*1)" to clean the gutter and the ink recovery route.

If the above actions (1) and (2) do not solve the issue, contact your nearest distributor.

(*1) UX2 : [Technical manual] 5.6 Cleaning Gutter

UX/RX2: [Technical manual] 6.6 Cleaning the Gutter

[v]

Guideline for the "Ink Replacement Cycle"

While the IJ printer ink circulates for operations, it reacts with atmospheric air elements and deteriorates with time. Therefore, it needs periodic replacement. Each ink has several guideline for the ink replacement cycle. Also, since the proper replacement intervals vary with the printer operating environmental conditions (temperature, humidity, dust, etc.). Please determine the best replacement cycle in accordance with the obtained printing results, and replace all ink in the printer with new ink.

[Note] The makeup must be filled to the printer within one year after opening the cartridge.
Note that basically the makeup filled to the printer needs no replacement.

(*1) UX2 : [Technical Manual] 5.3 Replacing the ink
UX/RX2: [Technical Manual] 6.3 Replacing the ink

[Guideline for ink replacement timing]

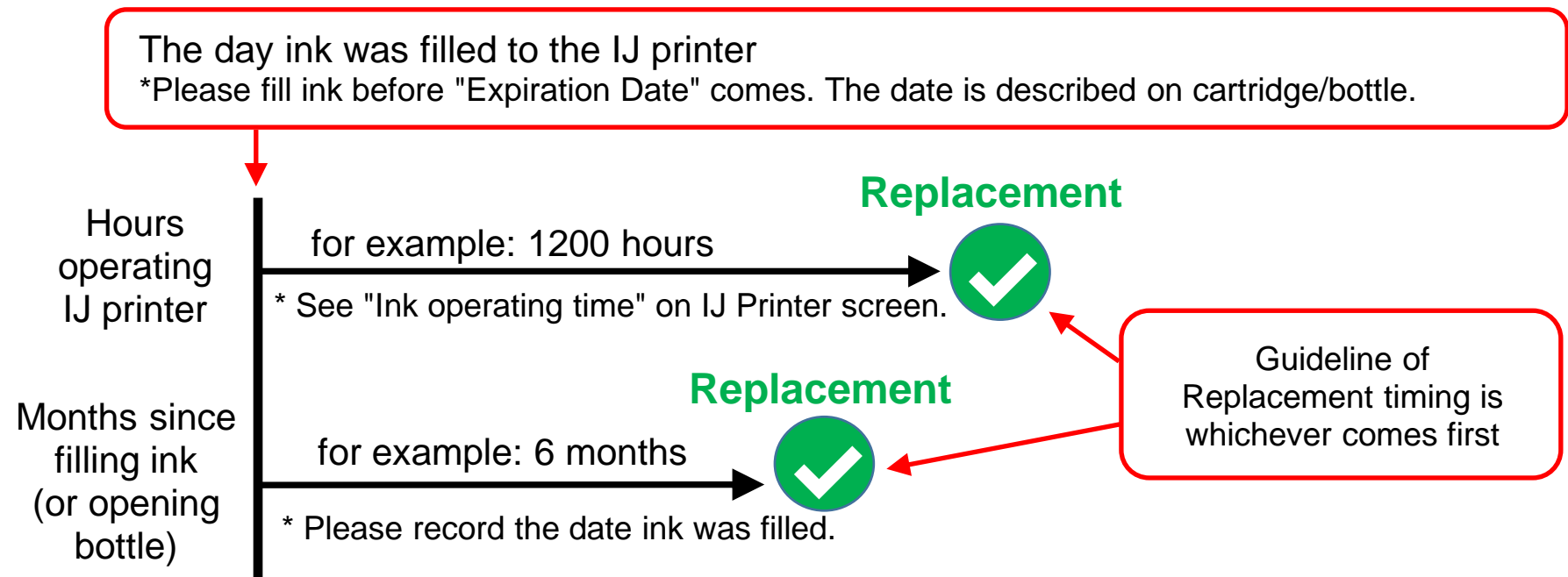

**[Remark] "Hours operating on IJ printer" and "Months since filling ink" are depend on Ink model.
Please refer to the attached document for each ink.**

[vi]

Stoppable Period and Long-term Shutdown

If the IJ printer is not operated on regular basis, ink may stick in circulation system. If it sticks, error such as ink not ejecting and ink can not be recovered are occur. To prevent these issues, refer to "IJ printer Stoppable period (*1)", and operate IJ printer (eject ink from the nozzle) on a regular basis. The period that can be stopped depends on the storage temperature. Also, please note that the period may be shorter dramatically depending on the usage environment(*2).

In case of long period shut down more than the term shown in "Stoppable period and Long-term shutdown", to operate "Long-term shutdown" is necessary. This long-term shutdown prevents sticking by draining the ink in the IJ printer and filling makeup (solvent) instead. Dedicated operation is required even when restarting. Please refer to the [Technical Manual (* 3)] for details of the operation.

(*1) Maximum period possible to be continuously shut down without operation.
it is necessary to operate it at least once during this period.

(*2) Please note that the ink may harden within a week if it is stored at 45 ° C or higher.

(*3) UX2 : [Technical manual] 6.16 Long-term shutdown
UX/RX2 : [Technical manual] 6.16 Long-term shutdown
UX(Twin nozzle) : [Technical manual] 6.15 Long-term shutdown
UX-P : [Technical manual] 6.15 Long-term shutdown
RX2 : [Technical manual] 6.14 Long-term shutdown

#NAME?



CAUTION

Since "Perform long-term shutdown storage work" requires special work, it is recommended to contact your local distributor and ask for the work.

**[Remark] "Days printer can be stopped" depend on Ink model.
Please refer to the attached document for each ink.**

[vii]

Required Operating Minimum Hours to Prevent Ink Viscosity Decrease

Following is precautions when repeating operation start and stop.

The IJ printer automatically cleans the circulation system with makeup (solvent) when stopped to prevent ink from sticking. At this time, the amount of solvent in the ink tank increases and the ink viscosity decreases. On the other hand, when the IJ printer is operated, the ink viscosity is automatically adjusted for stable operation. However, if the main tank is filled with a large amount of solvent by repeating "shutdown (automatic cleaning) in a short time", the ink viscosity may not be controlled normally. To prevent this, operate for a certain period of time (eject ink from nozzle) after starting operation. The required operating time depends on the ambient temperature and ink model.

[Note] For stable operation, limit the number of times "Shutdown" to be performed to two at a time.

[For example]

The table on the right showing the minimum required operating time is an example. In this case, if IJ printer is running under 20 °C ambient temperature, the required operating minimum hours is around 1 hour, after starting operation.

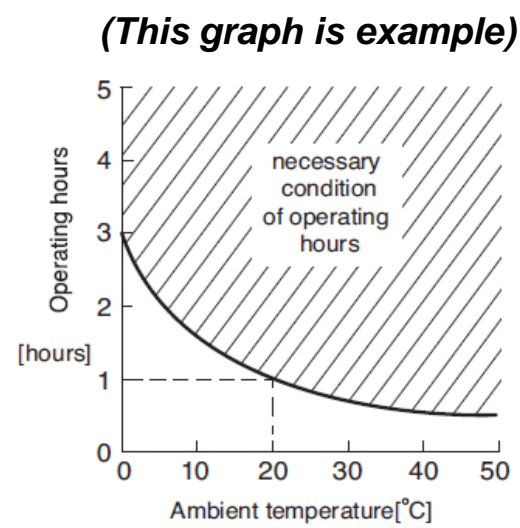

[Remark] "Required operating minimum hours" depend on Ink model. Please refer to the attached document for each ink.

Supplementary Information

In case of using "Rotary encoder" in order to match production speed and printing speed, "Excitation frequency" information is necessary(*1). This value depends on ink model, nozzle size and setting. Please see "Operating management" screen, and confirm the value of excitation frequency. In addition, applicable makeup and other information are shown also on the screen.

(*1) UX2 [Technical Manual] 4.3.2 Speed Matching Function Using Rotary Encoder

UX/RX2 [Technical Manual] 4.3.2-3 Method of calculating the conditions which allow product speed matching

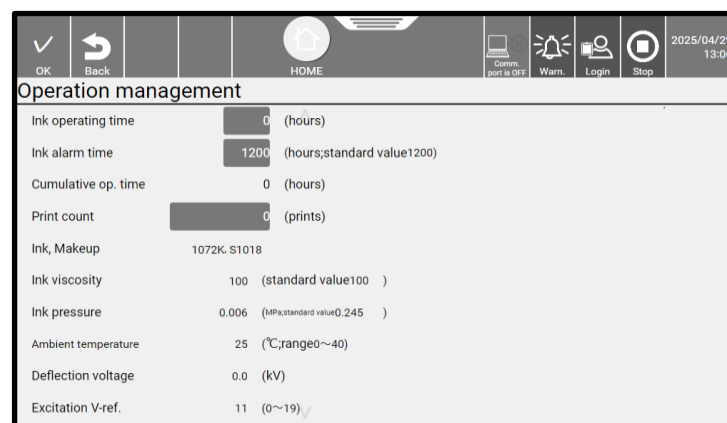

UX2 style screen

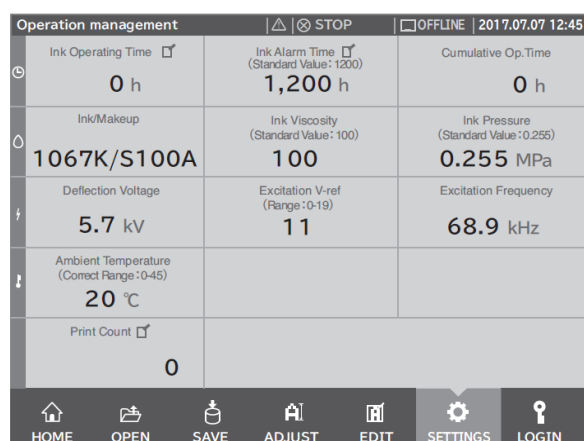

UX/RX2 style screen

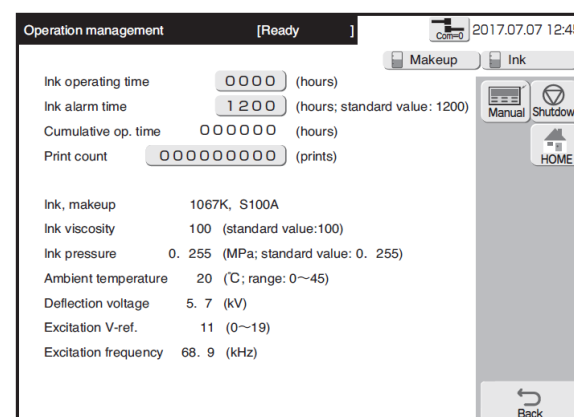

Classic style screen

Precautions (Basic precautions)

Note

For customer

Attachment for "Basic Precautions"

Detailed values for the following notes described in the main document depend on ink. Please refer to the contents described in the table of this document and use IJ printer and ink. Applicable makeup for each ink is described also.

- [v] Guideline for the "Ink replacement cycle"
- [vi] Stoppable period and Long-term shutdown
- [vii] Required operating minimum hours to prevent ink viscosity decrease

※ Depending on the ink, there may be special precautions. In this case, please see "Precaution for each ink" also.

Value of "Basic precautions [v], [vi] and [vii]" for each ink

1069K / JP-K69

Applicable Makeup	S1069 / TH-69	Base solvent	MEK
-------------------	---------------	--------------	-----

[v]	Guideline for the "Ink replacement cycle"	
Guideline of replacement timing to new ink is the earlier of the following.		
	Hours operating on IJ printer	Months since filling ink (or opening bottle)
	600 - 1200 hours	6 months

[vi]	Stoppable period and Long-term shutdown			
Guidelines for stoppable period (Days printer can be stopped)				
	Storage temperature	0-35°C	35-40°C	40-45°C
	Days printer can be stopped	21 days	14 days	7 days

[vii]	Required operating minimum hours to prevent ink viscosity decrease	
Please operate IJ printer for at least following hours per start-up of IJ printer.		
	For single nozzle	For Twin nozzle ((UX-D860J/W))
Estimated operating hours		

For customer

Precautions for each ink

Following items are precautions for each ink. In order to prevent errors, please be sure to check following matters before installing. In addition, please see "Basic Precautions" also.

Precaution Number	Precautions for ink 1069K / JP-K69
-------------------	--

B01	Stirring before using ink <for carbon inks>
Detail	This ink contains carbon black(pigment) as color material. Carbon black settle on bottom of cartridge/bottle. Before using ink(Filling, replenishment and ink replacement), please shake cartridge/bottle and re-disperse settled carbon black. If stirring is not enough, color density would be light.

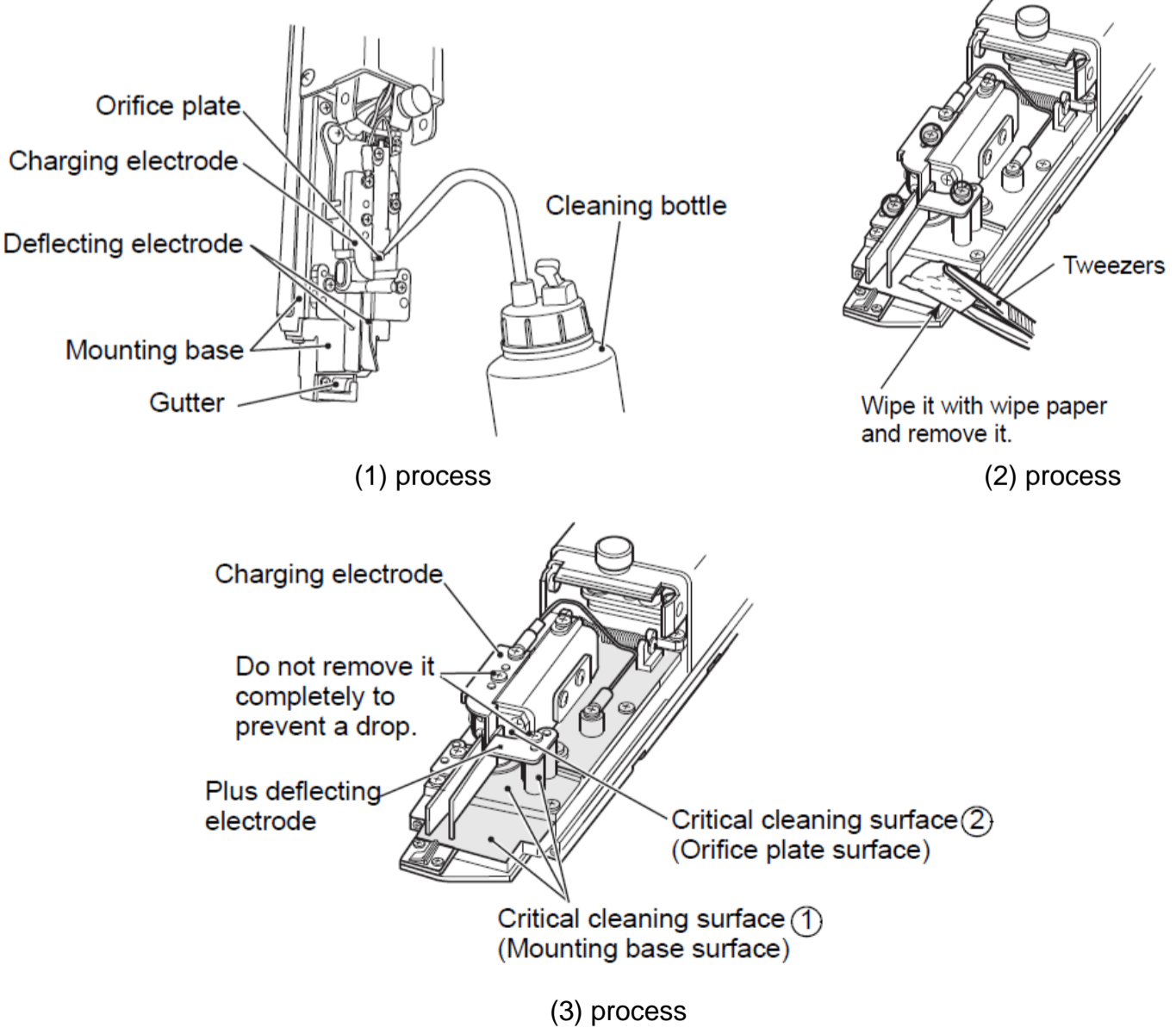
D02	Print head cleaning method in case of using carbon inks
Detail(1)	<p>If ink stains is found on the orifice, charging electrodes, deflecting electrodes, gutter and other points on inside of print head, please clean them enough. This ink contains carbon black as colorant, and it has conductivity. Therefore, if print head is stained with ink, electricity leak may appear. Especially, this error appear around deflecting electrodes. If the charge error is appears even though the ink particles are created well, check the inside of print head for dirt, and clean it by referring to the following if necessary. (Shape of each electrode and gutter mounting base differs depending on the model, but the cleaning method is not different.)</p> <p style="text-align: center;"><Cleaning method></p> <ol style="list-style-type: none">(1) After the operation is stopped, using cleaning bottle and pour and clean with makeup on the orifice, charging electrodes, deflecting electrodes, gutter and other points on inside of print head.(2) Wipe off carbon black and makeup from the each point(including the mounting base) with paper wipers and dry them.(3) If alarm is shown after this cleaning process, there is possibility that carbon black is still remains on the mounting base and electricity leak appears. In this case, remove the plus deflecting electrode, and wipe mounting base surface with paper wipe dampened with makeup.  <p>Orifice plate Charging electrode Deflecting electrode Mounting base Gutter</p> <p>Cleaning bottle</p> <p>Tweezers</p> <p>Wipe it with wipe paper and remove it.</p> <p>(1) process</p> <p>(2) process</p> <p>Charging electrode</p> <p>Do not remove it completely to prevent a drop.</p> <p>Plus deflecting electrode</p> <p>Critical cleaning surface ② (Orifice plate surface)</p> <p>Critical cleaning surface ① (Mounting base surface)</p> <p>(3) process</p>

< Cleaning method (for twin nozzle) >

- (1) After the operation is stopped, using cleaning bottle and pour and clean with makeup on the orifice, charging electrodes, deflecting electrodes, gutter and other points on inside of print head.

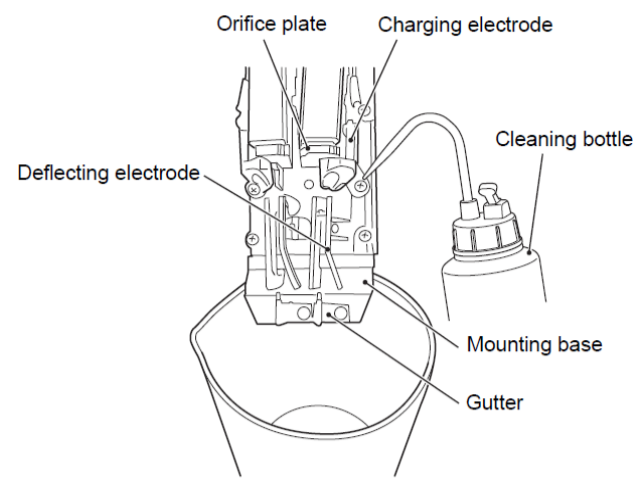

- (2) Loosen and remove the screws of the deflection electrodes ① to ④. Wipe off carbon black and makeup from the each point(including the mounting base) with paper wipers and dry them.

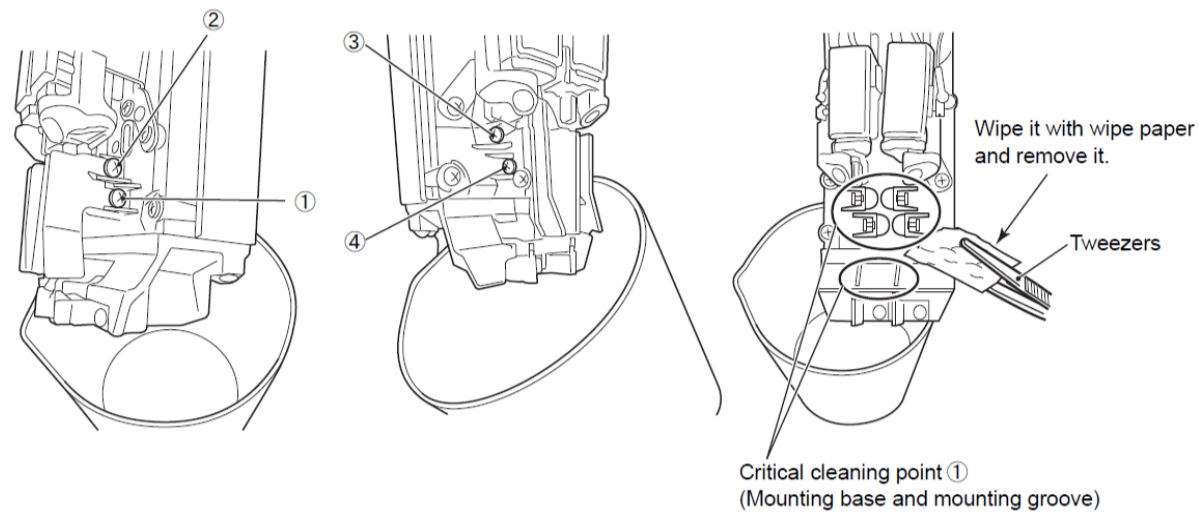

⚠ Caution

- Since the component spacing is narrow, cleaning without removing deflecting electrodes may cause deformation.
- If deflecting electrodes or charging electrodes are deformed, printing disorder or error may occur.

- (3) After removing the charging electrode, clean the surface of the orifice plate in the same way.

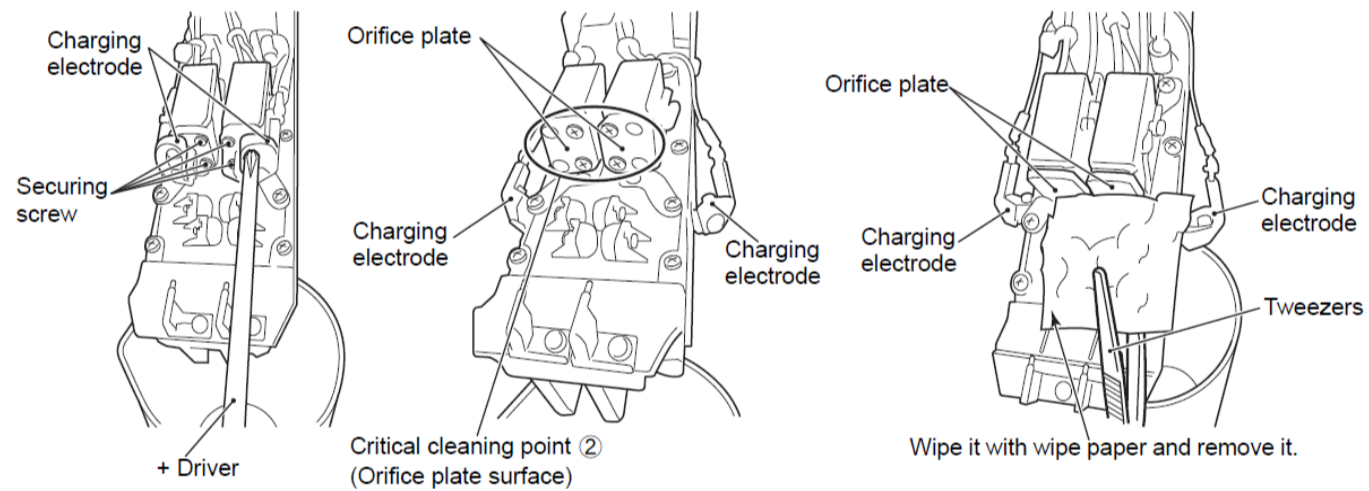

⚠ Caution

- Be careful not to damage the spout of the orifice plate with pliers.
- Be careful not to lose the securing screw of the charging electrode.

- (4) After completion of cleaning, please dry the inside of print head thoroughly and install parts with the reverse procedure.

⚠ Caution

- If any trouble occurs after cleaning work, please contact the nearest service station.